

**8- AXLE CONVENTIONAL: 47' TILT FRAME  
BRIDGE LEGAL, 154,000 GVW / OUTSIDE RAILS**

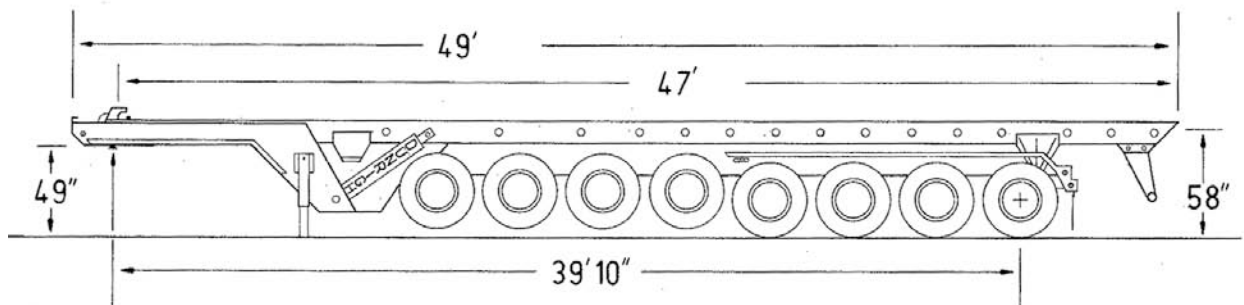

**MAIN FRAME:**

16' x 45 lb wide flange beam (50,000 lb minimum yield), 1/4" reinforcement wash plate full length of frame. 1/2" king pin plate (50,000 lb minimum yield). Cross members - 12" channel, 12 1/2" suspension flanges (50,000 lb minimum yield).

35083 Cordelia St., Clinton Township, MI 48035 TOLL-FREE (800) 268-8141  
Phone: (586) 791-1830 Fax: (586) 791-8070 Email: sales@dunright.net  
www.dunright.net

## 8- AXLE CONVENTIONAL: 47' TILT FRAME BRIDGE LEGAL, 154,000 GVW / OUTSIDE RAILS

### TILT FRAME:

12" x 4" x 1/2" (50,000 lb minimum yield) tube, 1/2" wear rail, 5/8" tension strap. Tilt frame guides front and center, intermittent container stops, and safety props. Container hold down straps, hooks, and winches - 4 per side.

### AXLES:

Meritor-Rockwell (25,000 lb capacity), auto slack.

### BRAKE VALVES:

Meritor-Sealco ABS brake system, per federal requirements.

### SUSPENSION:

Hutch 9700 series, cast steel. Watson Chalin liftable axle.

### HYDRAULICS:

Parker Commercial hydraulic valve, 2 spools. **Hoses:** 1" x 3000 psi.  **tubing:** 1" heavy wall. **Fittings:** Parker ferulock.

### HYDRAULIC CYLINDERS:

Custom Hoist hard chrome plated. **Hoist cylinders:** DAT 85"- 220" stroke telescopic. **Reeving cylinders:** DA 7" - 152" stroke (75,000 lb capacity).

### ELECTRICAL:

LED lighting. Sealed harness (no splices or junction boxes).

### FENDERS:

Full front and rear steel fenders.

### TIRES:

11R X 225 steel belted radial on 10-hole hub piloted wheels (white).

### LANDING GEAR:

Holland Mark V landing gear (200,000 lb capacity).

### CABLE:

7/8" x 135' alternate lay with oblong ring.

### SHEAVES:

5 sheaves, 12" with oil-light bronze grease grooves. Greasable.

### ROLLERS AND PINS:

2" 1045 surface hardened steel. **Rollers:** 16 per side, 4" x 4" x 2", oil light bronzed, bushed. Greasable.

### ICC BUMPER:

Locking automatic (no hydraulics), per federal requirements.

### PAINT:

Painted black, sandblasted, and primed. Other colors optional.

### OPTIONS:

Stinger tail, liftable axle, auto tarp system, inside/outside rails, toolbox, dead lifts, 1" cable and sheaves. Other options available, please call for details.