

**2 - AXLE CONVENTIONAL: 38' TILT FRAME
BRIDGE LEGAL, 76,000 GVW / OUTSIDE RAILS**

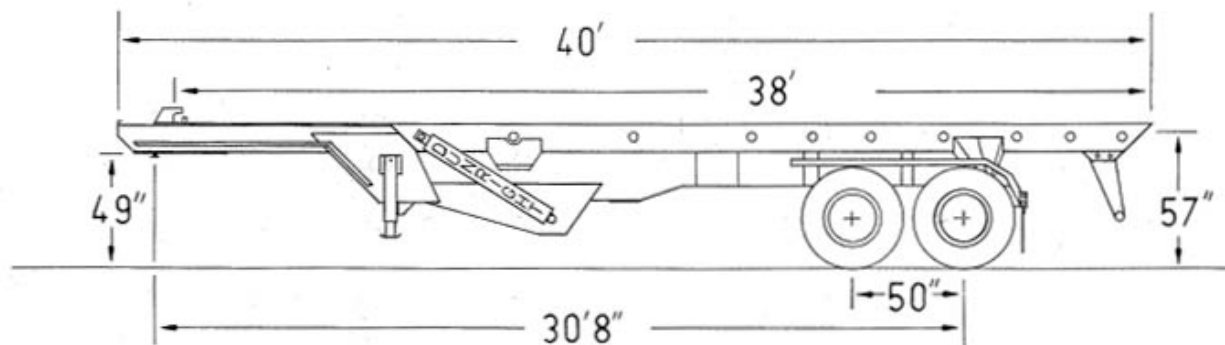

MAIN FRAME:

21' x 44 lb wide flange beam (50,000 lb minimum yield), tapered and reinforced.
1/2" x 11 1/2" suspension flanges (50,000 lb minimum yield). King pin plate 1/2" (50,000 lb minimum yield). Cross members - 16" x 4" + 9" x 4" (fabricated).

TILT FRAME:

12" x 4" x 3/8" tube (50,000 lb minimum yield), 1/2" wear rail.
Tilt frame guides front and center, intermittent container stops, and safety props.
Container hold down straps, hooks, and winches - 2 per side.

AXLES:

Meritor-Rockwell 25,000 lb capacity, auto slack.

BRAKE VALVES:

Meritor-Sealco ABS brake system, per federal requirements.

**2 - AXLE CONVENTIONAL: 38' TILT FRAME
BRIDGE LEGAL, 76,000 GVW / OUTSIDE RAILS**

SUSPENSION:

Hutch 9700 series, cast steel. Watson Chalin liftable axle (optional).

HYDRAULICS:

Parker Commercial hydraulic valve, 2 spool. **Hoses:** 1" x 3000 psi. **Tubing:** 1" heavy wall. **Fittings:** Parker ferulock.

HYDRAULIC CYLINDERS:

Custom Hoist hard chrome plated. **Hoist cylinders:** DAT 63" - 152" stroke telescopic. **Reeving cylinders:** DA 7" - 130" stroke (75,000 lb capacity).

ELECTRICAL:

LED lighting. Sealed harness (no splices or junction boxes).

FENDERS:

Full front and rear steel fenders.

TIRES:

11R X 225 steel belted radial on 10-hole hub piloted wheels (white).

LANDING GEAR:

Holland Mark V landing gear (200,000 lb capacity).

CABLE:

7/8" x 115' alternate lay with oblong ring.

SHEAVES:

5 sheaves, 12" with oil-light bronze grease grooves. Greasable.

ROLLERS AND PINS:

2" 1045 surface hardened steel. **Rollers:** 12 per side, 4" x 4" x 2", oil light bronzed, bushed. Greasable.

ICC BUMPER:

Locking automatic (no hydraulics), per federal requirements.

PAINT:

Painted black, sandblasted, and primed. Other colors optional.

OPTIONS:

Stinger tail, liftable axle, auto tarp system, inside/outside rails, toolbox, dead lifts, 1" cable and sheaves. Other options available, call for details.